

MU-INT (PT-1507D) SIDE A

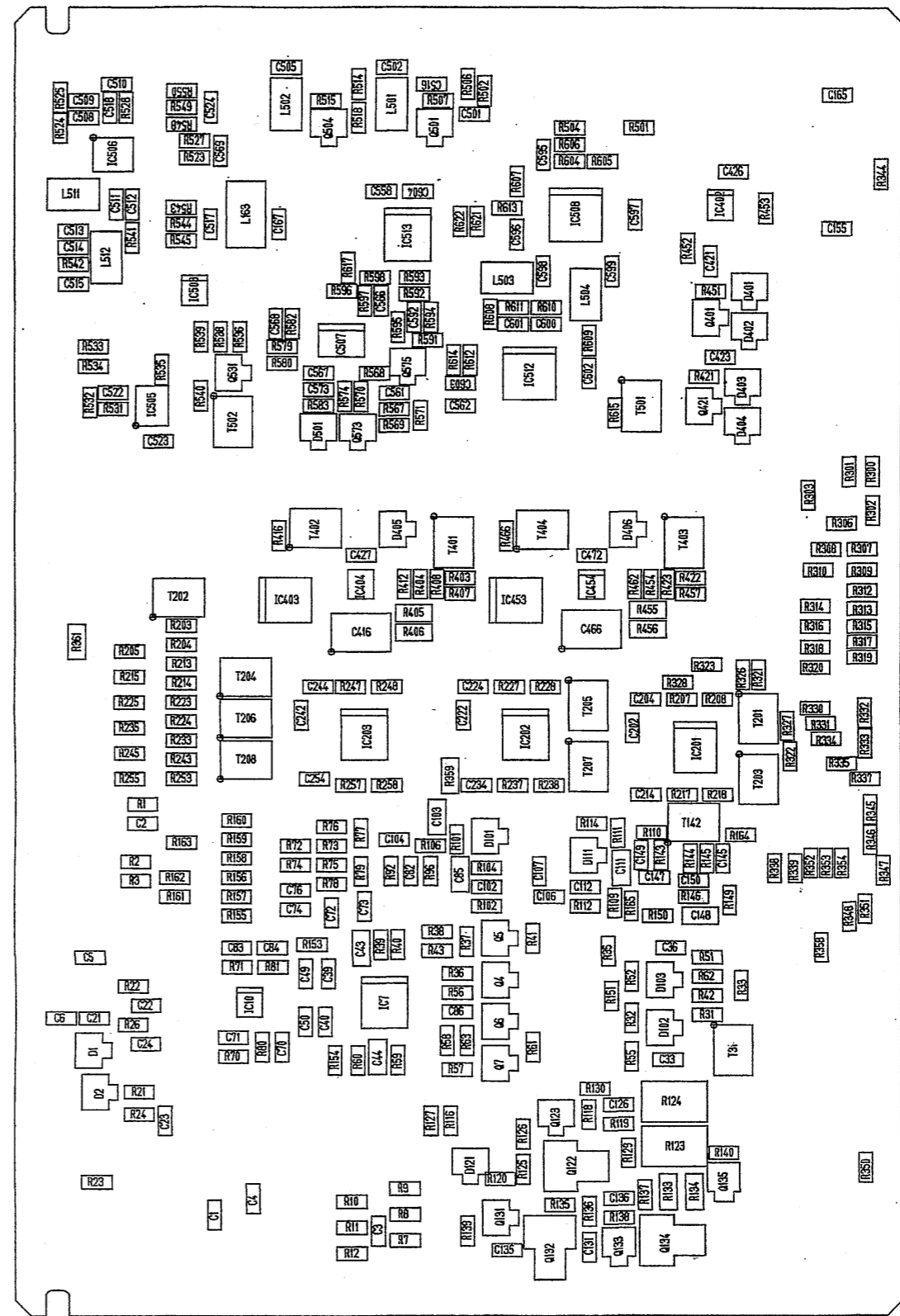

MU-INT (PT-1507D) SIDE B

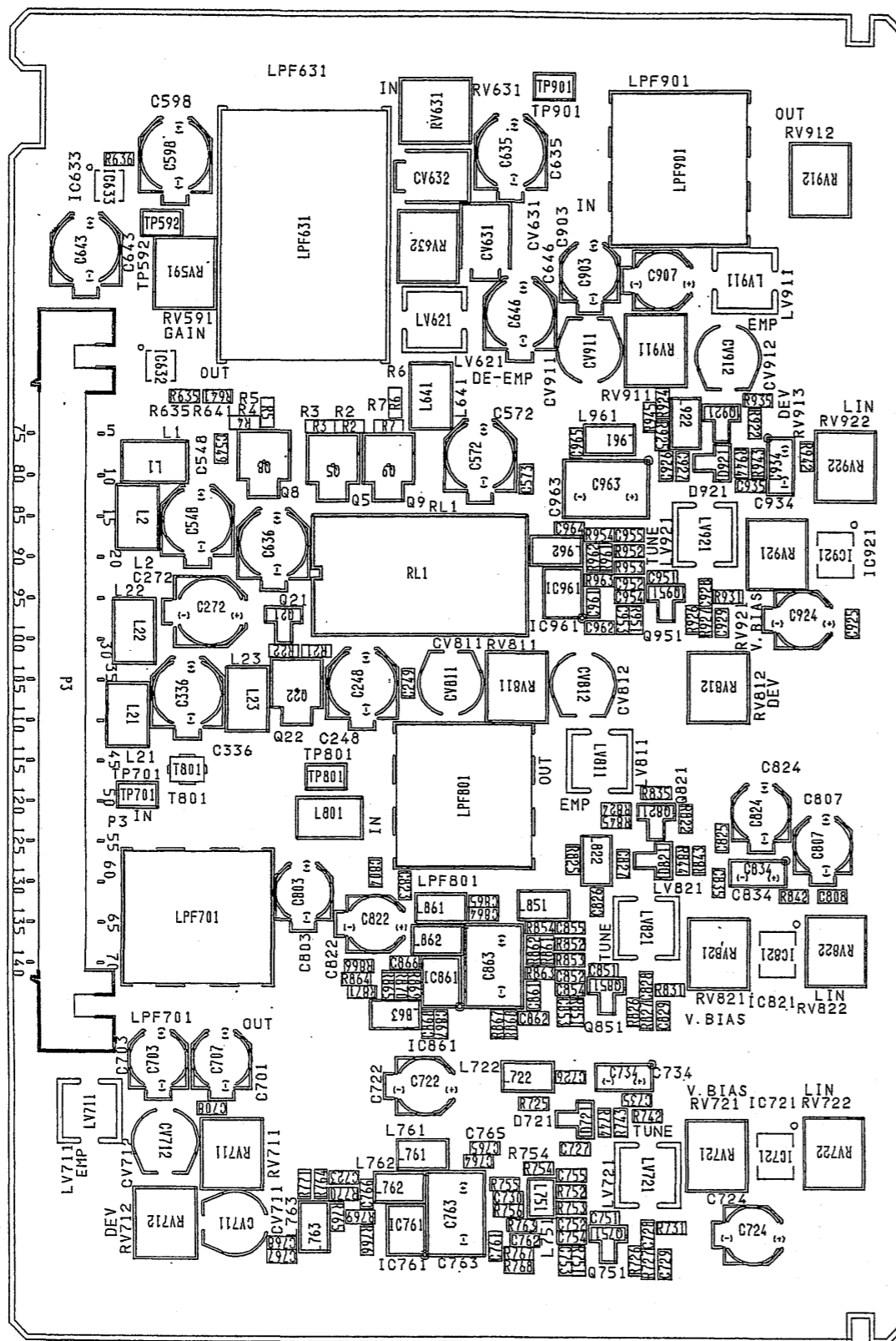

MU-MOD (PT-1504D) SIDE A

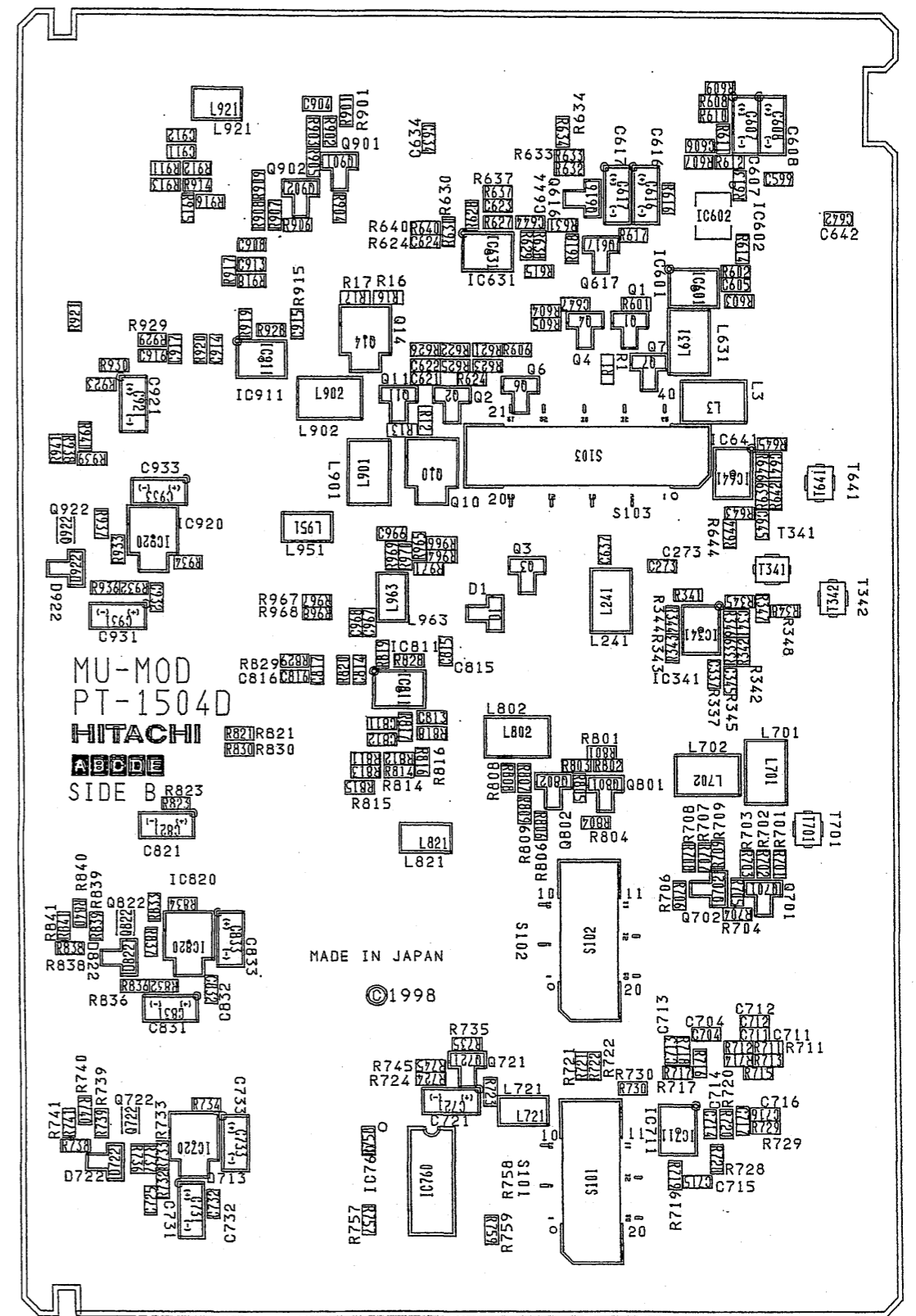

MU-MOD (PT-1504D) SIDE B

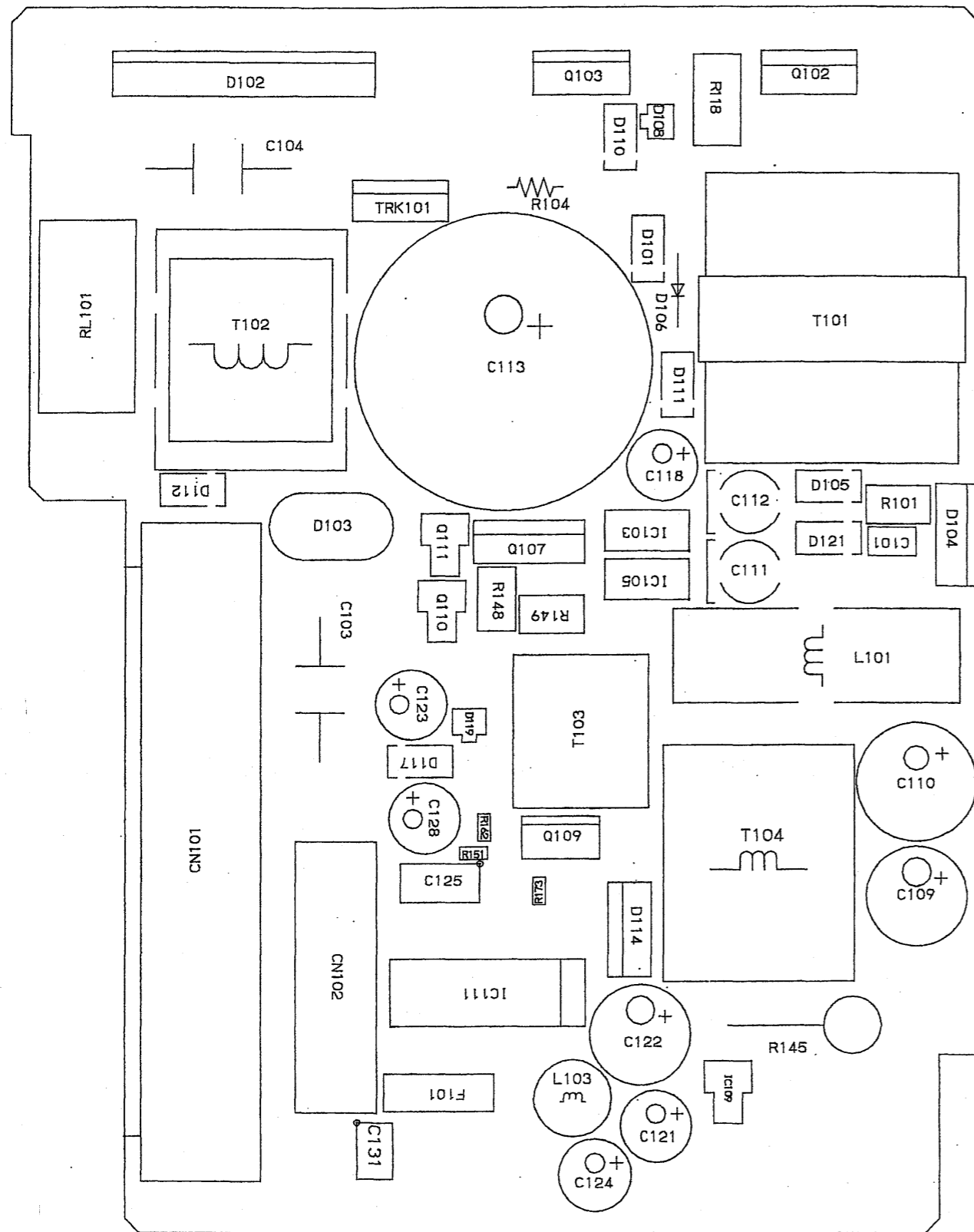

MU-POWER (PT-1508C) SIDE A

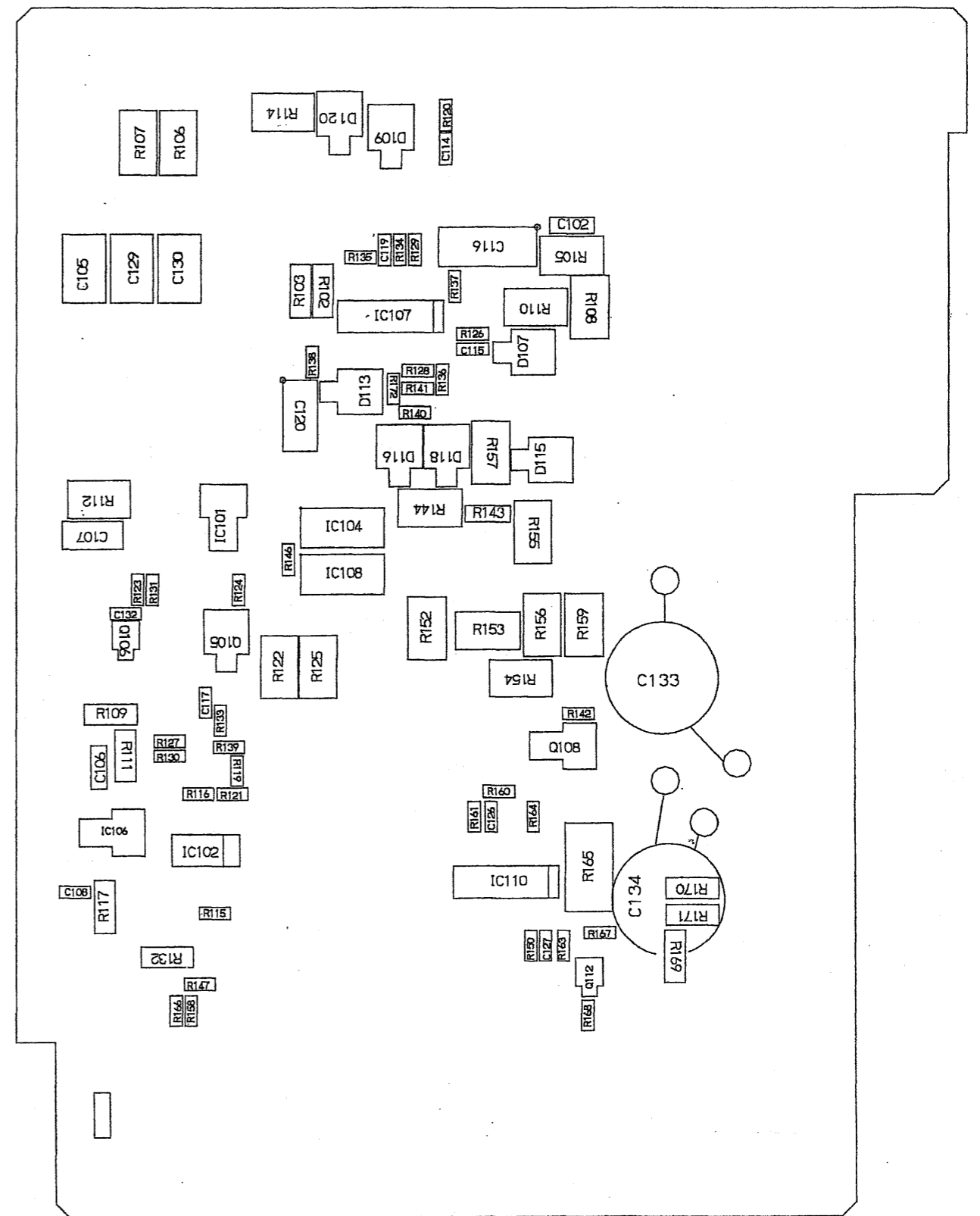

MU-POWER (PT-1508C) SIDE B

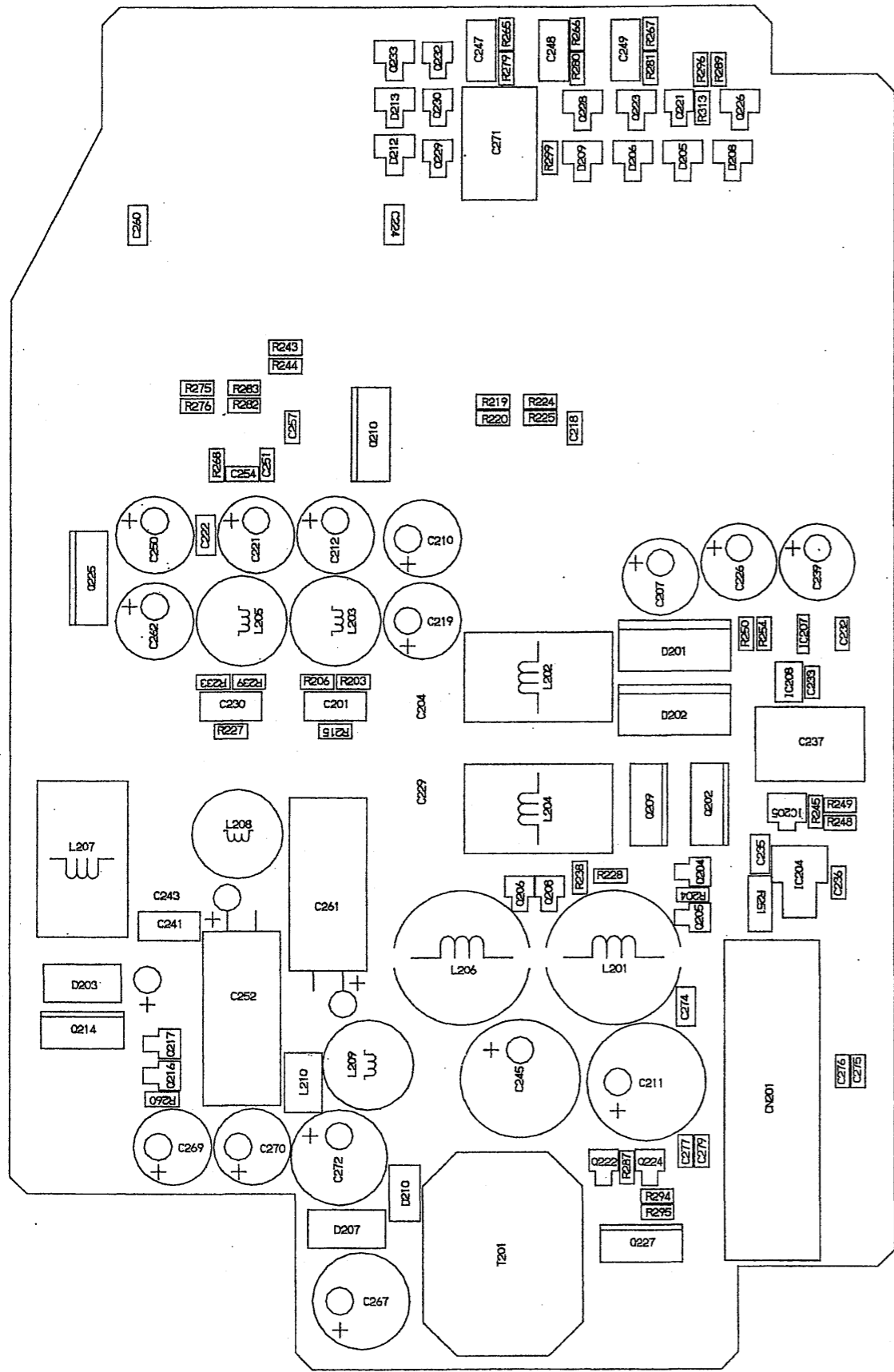

MU-REG (PT-1509C) SIDE A

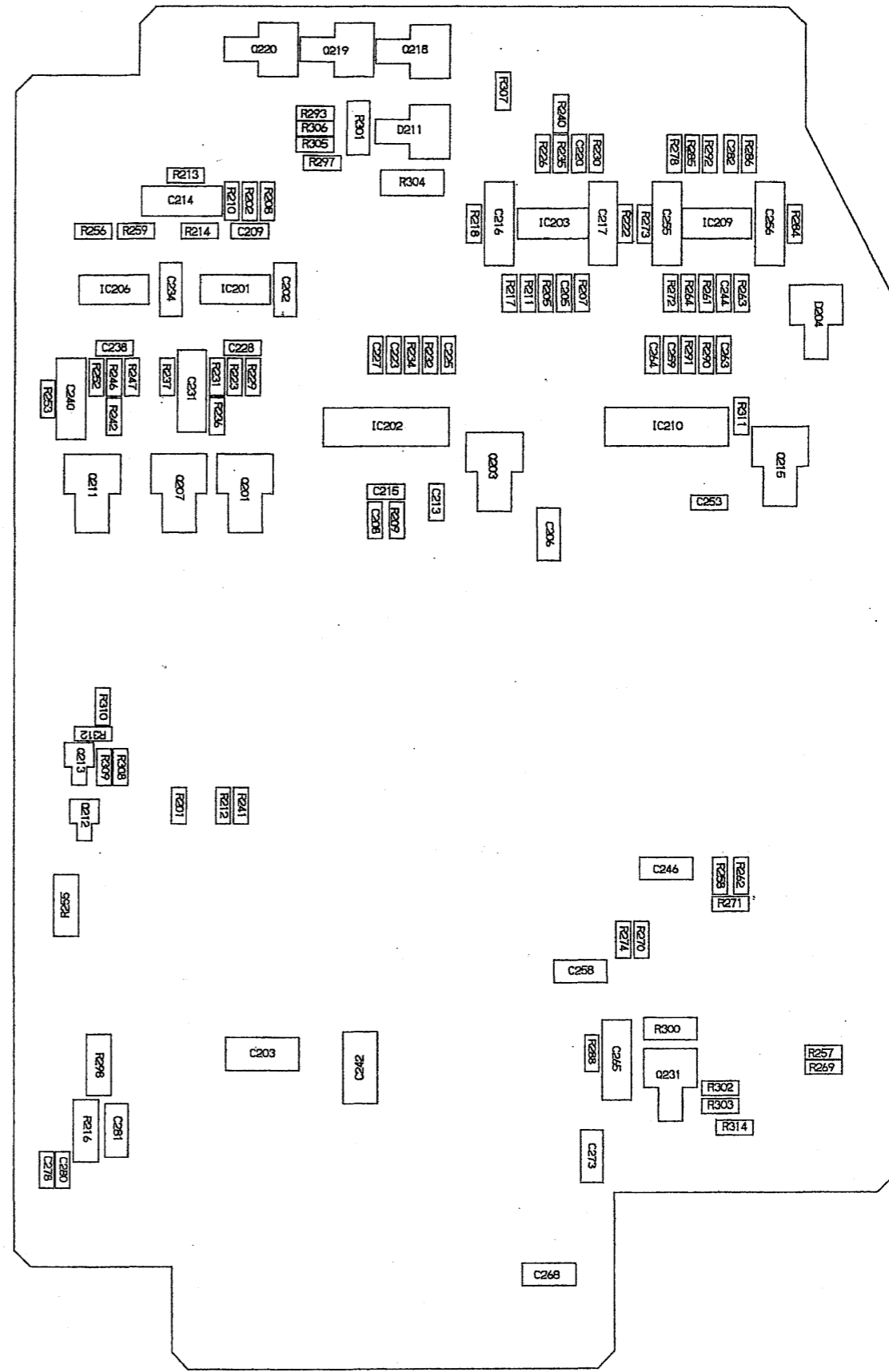

MU-REG (PT-1509C) SIDE B

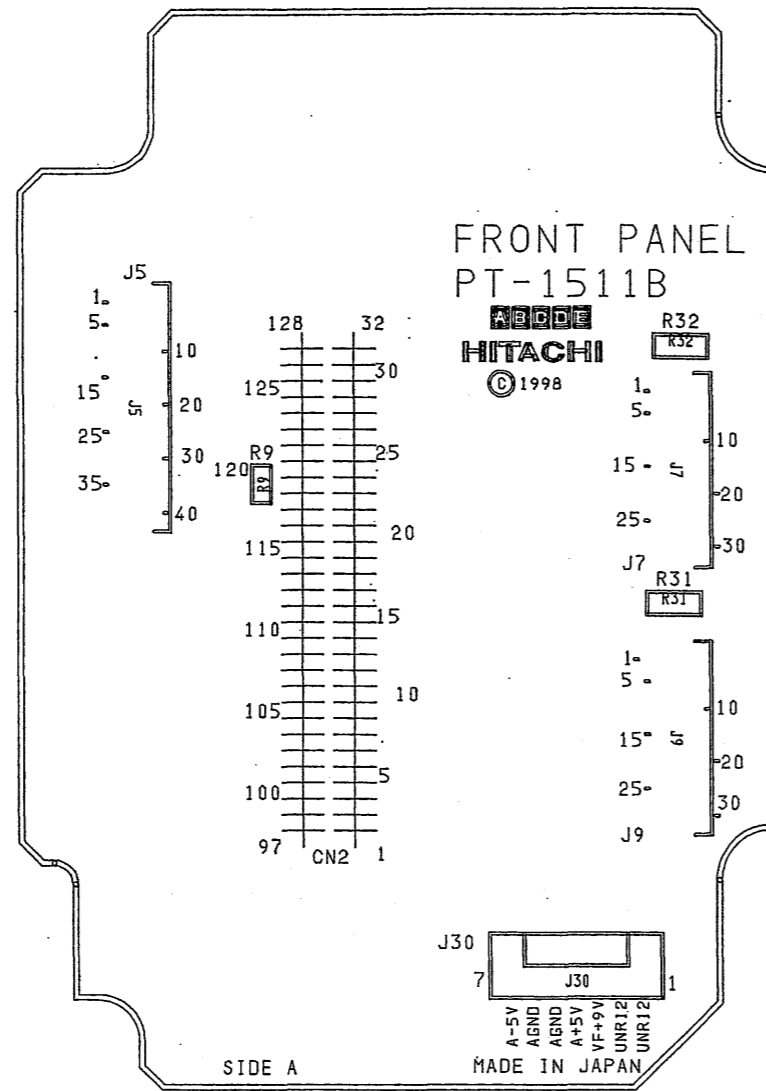

FRONT PANEL (PT-1511B) SIDE A

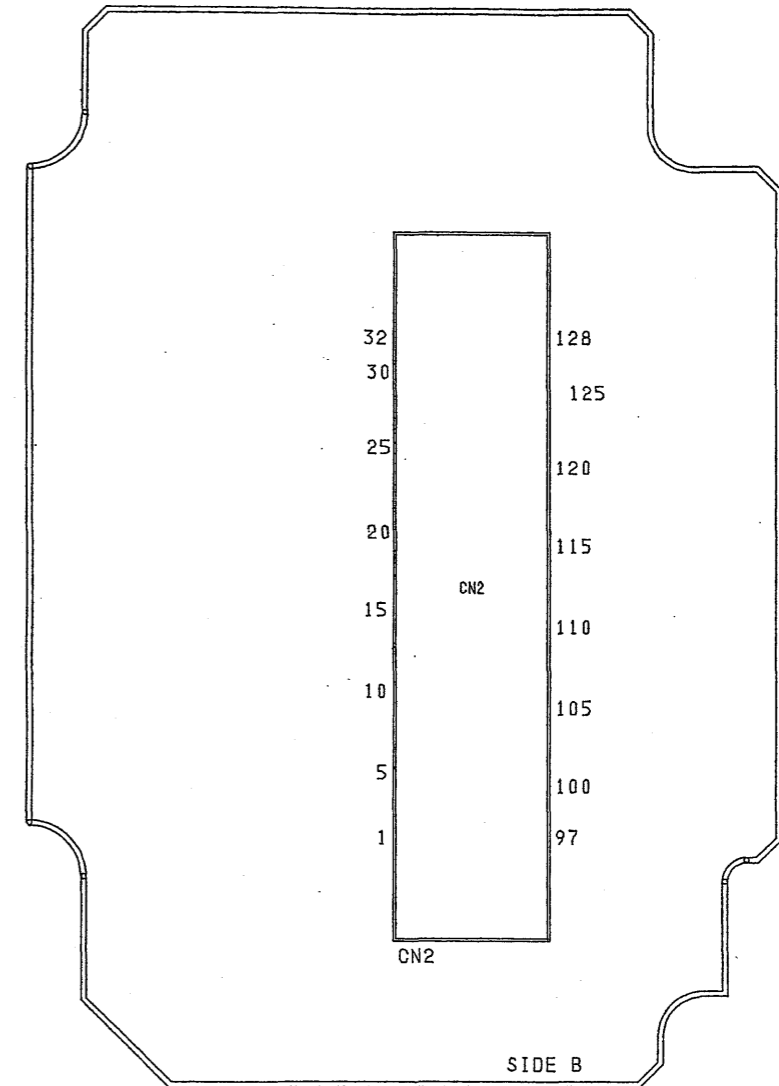

FRONT PANEL (PT-1511B) SIDE B

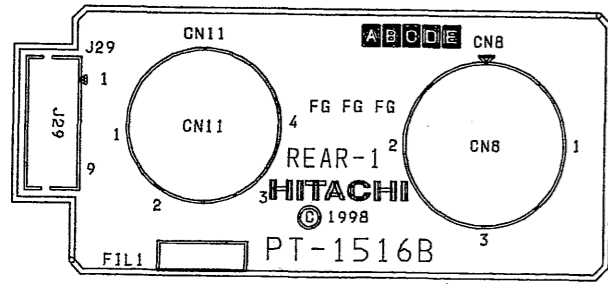

REAR 1 (PT-1516B) SIDE A

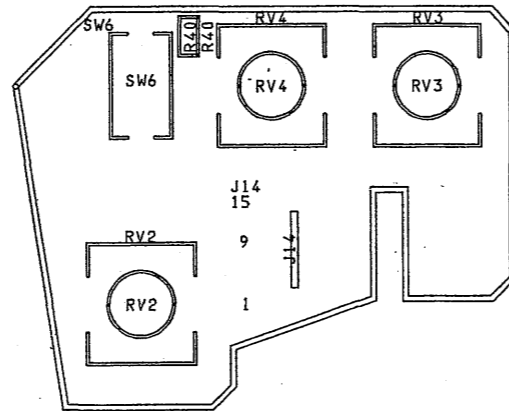

INCOM SW (PT-1514B) SIDE A

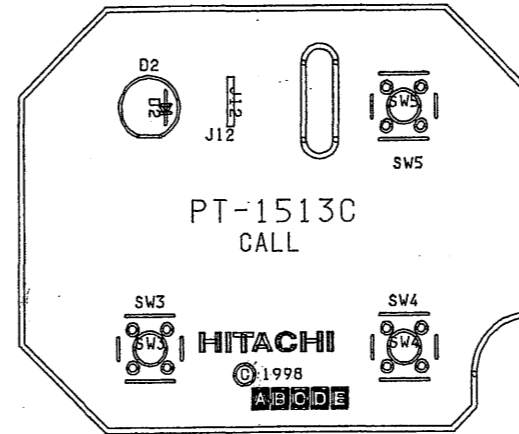

CALL (PT-1513C) SIDE A

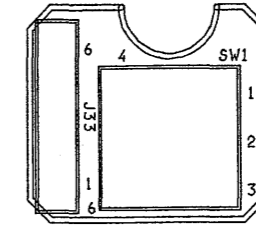

PWR SW (PT-1517A) SIDE A

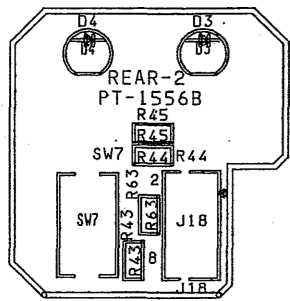

REAR 2 (PT-1556B) SIDE A

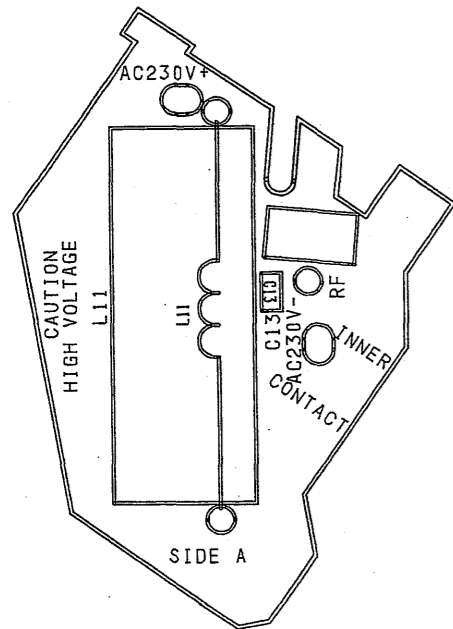

FIL-AC (PT-1558B) SIDE A

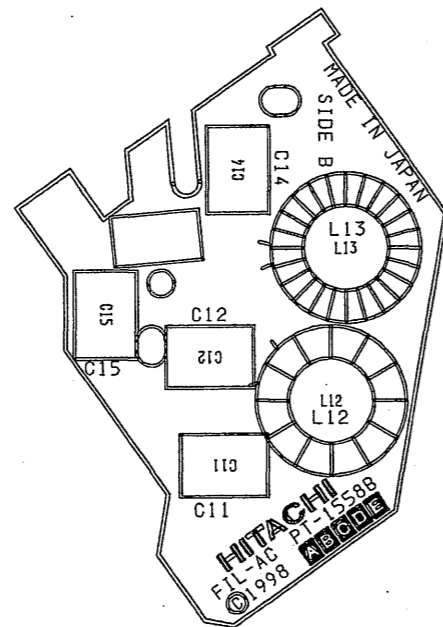

FIL-AC (PT-1558B) SIDE B

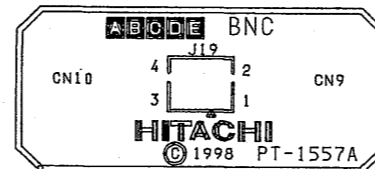

BNC (PT-1557A) SIDE A

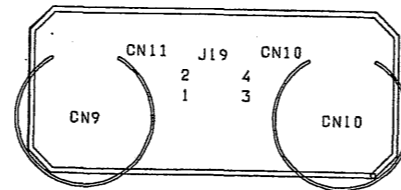

BNC (PT-1557A) SIDE B

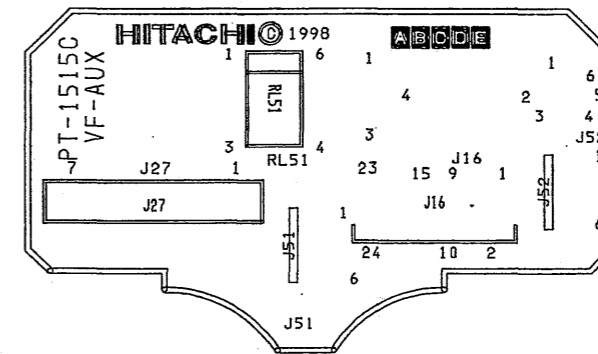

VF-AUX (PT-1515C) SIDE A

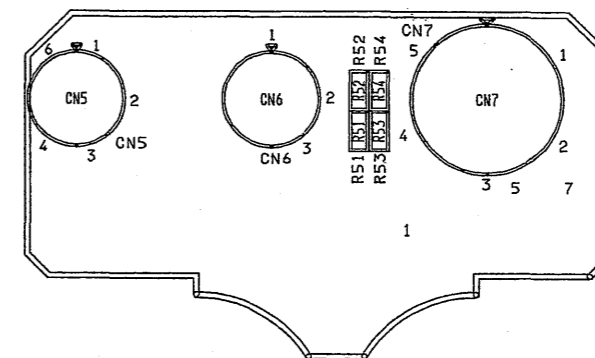

VF-AUX (PT-1515C) SIDE B

8. EXPLODED VIEW & PARTS LIST

1. TU-Z3

| | |
|------------------------------|--------|
| EXPLODED VIEW | 8-1-1 |
| MECHANICAL PARTS LIST | 8-1-3 |
| ELECTRICAL PARTS LIST | |
| TU-VIDEO unit | 8-1-4 |
| MEMORY unit | 8-1-8 |
| TU-PWR/INCOM unit | |
| POWER | 8-1-12 |
| INCOM | 8-1-13 |
| DU-MOD/DEM unit | 8-1-17 |
| DU-CHASSIS | 8-1-23 |
| TU-RECT unit | 8-1-24 |
| TU-RECT SUB unit | 8-1-25 |
| INCOM/LED unit | 8-1-26 |
| REMOTE unit | 8-1-26 |
| TU-BNC unit | 8-1-26 |
| TU-CHASSIS | 8-1-27 |
| TU-DC IN | 8-1-27 |
| MIC unit | 8-1-27 |
| TU-FIL-AC unit | 8-1-27 |
| TU-MB unit | 8-1-27 |
| ACCESSORIES | 8-1-27 |
| D1 DIGITAL unit [OPTION] | 8-1-28 |
| DIGBNC SUB unit [OPTION] | 8-1-30 |
| DIGBNC unit [OPTION] | 8-1-30 |
| ACCESSORIES [OPTION] | 8-1-30 |

2. CX-Z3

| | |
|------------------------------|--------|
| EXPLODED VIEW | 8-2-1 |
| MECHANICAL PARTS LIST | 8-2-3 |
| ELECTRICAL PARTS LIST | |
| CX-MB unit | 8-2-4 |
| MU-DIGITAL unit | 8-2-5 |
| CX-INT unit | |
| SYNC | 8-2-8 |
| MIC | 8-2-9 |
| INTERCOM | 8-2-10 |
| MU-MOD unit | 8-2-12 |
| MU-DEM unit | 8-2-16 |
| MU-POWER unit | 8-2-20 |
| MU-PWR SUB unit | 8-2-20 |
| MU-REG unit | 8-2-21 |
| CX-CHASSIS | 8-2-23 |
| FRONT PANEL unit | 8-2-23 |
| PWR SW unit | 8-2-23 |
| CX-FIL-AC unit | 8-2-23 |
| VF AUX unit | 8-2-23 |
| INCOM-SW unit | 8-2-23 |
| CALL unit | 8-2-23 |
| REAR1 | 8-2-23 |
| REAR2 | 8-2-23 |
| BNC | 8-2-23 |

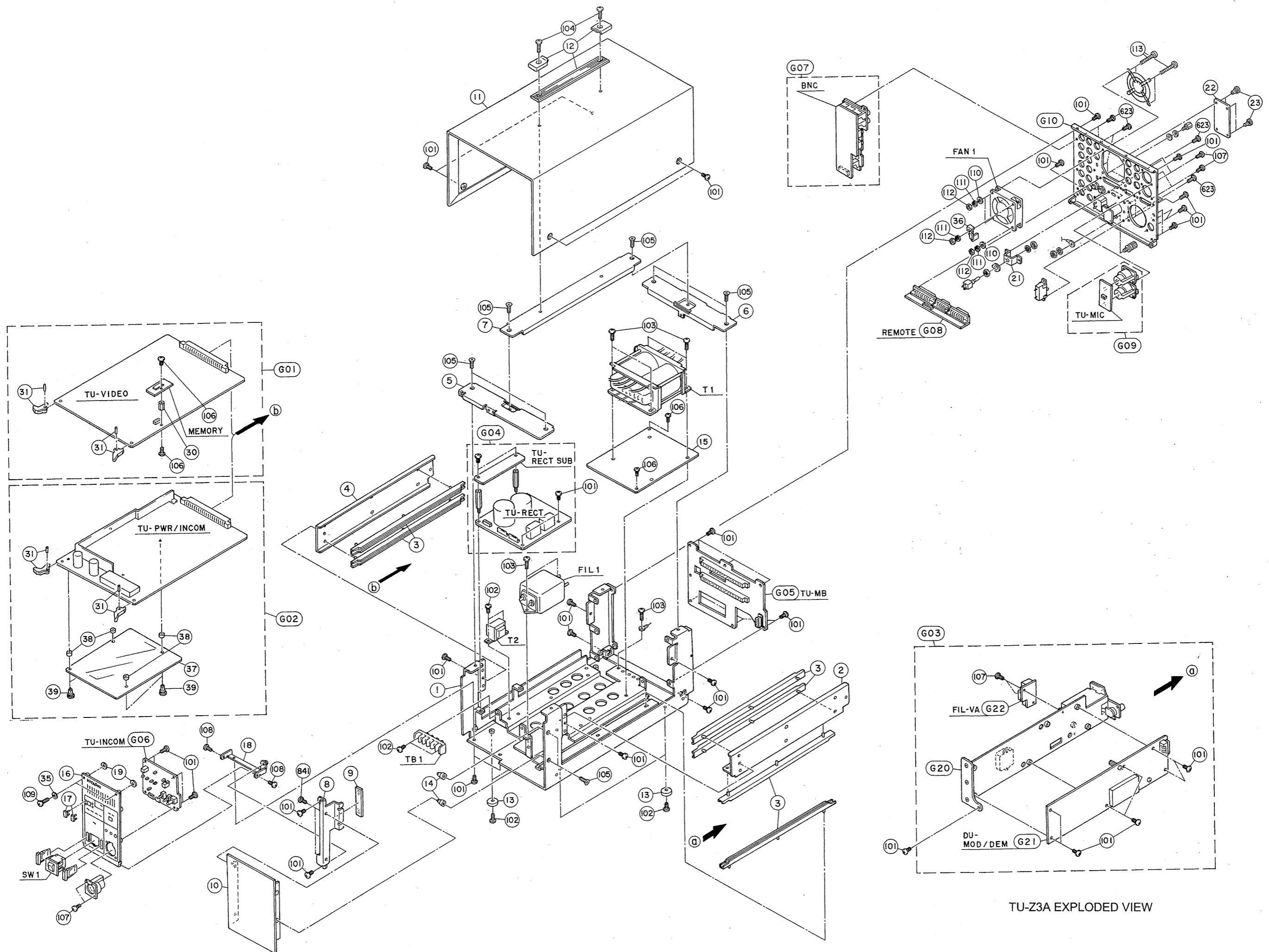

TU-Z3A EXPLODED VIEW

TU-Z3A MECHANICAL PARTS LIST

| SYMBOL | PART CODE | DESCRIPTION | Q'ty |
|--------|-----------|---------------------------|------|
| 1 | 22M0271 | FRAME ASSY | 1 |
| 2 | 3413005A | GUIDE RAIL BRACKET | 1 |
| 3 | 8672646A | GUIDE RAIL | 6 |
| 4 | 3413006A | GUIDE RAIL BRACKET | 1 |
| 5 | 3413008AA | BRACKET (FRONT) | 1 |
| 6 | 3413007A | BRACKET (REAR) | 1 |
| 7 | 3413010A | BRACKET | 1 |
| 8 | 8669258A | PCB BRACKET | 1 |
| 9 | 8673768A | RUBBER | 1 |
| 10 | 3413011AA | BLANK PANEL | 1 |
| 11 | 2160942A | COVER | 1 |
| 12 | XCF0428 | HANDLE | 1 |
| 13 | XCZ0025 | FOOT | 4 |
| 14 | 8673753A | GUIDE | 2 |
| 15 | 8672668A | LINE COVER | 1 |
| 16 | 3413012BB | OPERATION PANEL | 1 |
| 17 | 8671207A | SW GUARD | 2 |
| 18 | 8669264AA | BRACKET | 1 |
| 19 | 8651916A | WASHER | 2 |
| 21 | 8669256A | SW BRACKET | 1 |
| 22 | 8669290A | BNC COVER | 1 |
| 23 | 8412742A | PLASTIC RIVET | 2 |
| 30 | 8644999C | SPACER | 1 |
| 31 | 8552390A | EJECTOR | 4 |
| 35 | 8651916B | WASHER | 2 |
| 36 | 8675962A | BRACKET | 1 |
| 37 | 3416351A | PLATE SHIELD | 1 |
| 38 | 8676009A | COLLAR | 4 |
| 39 | 8657336K | PLASTIC RIVET | 4 |
| 101 | XCA6306 | SCREW BIND HD M3X6 NIP | 50 |
| 102 | XCA6308 | SCREW BIND HD M3X8 NIP | 8 |
| 103 | XCA6412 | SCREW BIND HD M4X12 NIP | 8 |
| 104 | XCA6412 | SCREW BIND HD M4X12 NIP | 6 |
| 105 | XCA7306 | SCREW FLAT HD M3X6 NIP | 14 |
| 106 | XCA6204 | SCREW BIND HD M2X4 NIP | 17 |
| 107 | XCA1656 | SCREW BIND HD M2.6X6 DNIP | 16 |
| 108 | XCA1817 | SCREW BIND HD M3X6 DNIP | 2 |
| 109 | XCA1821 | SCREW BIND HD M3X12 DNIP | 2 |
| 110 | XCA1857 | WASHER NIP | 4 |
| 111 | XCA1881 | SPRING WASHER NIP | 4 |
| 112 | XCA1707 | NUT NIP | 4 |
| 113 | XCA6430 | SCREW BIND HD M4X30 NIP | 4 |
| 623 | XCA1817 | SCREW BIND HD M3X6 DNIP | 16 |
| 841 | XCA0689 | SCREW W/W,SW SEMS M3X6 | 2 |

| SYMBOL | PART CODE | DESCRIPTION | Q'ty |
|--------|-----------|--------------------------------------|------|
| G01 | 24X0296 | TU-VIDEO/MEMORY ASSY (FOR NTSC) | 1 |
| G01 | 24X0297 | TU-VIDEO/MEMORY ASSY (FOR PAL) | 1 |
| G02 | 24X0254 | TU-PWR/INCOM | 1 |
| G03 | 24X0255 | DU-MOD/DEM CHASSIS ASSY (FOR KINGS) | 1 |
| G03 | 24X0272 | DU-MOD/DEM CHASSIS ASSY (FOR FISGER) | 1 |
| G03 | 24X0273 | DU-MOD/DEM CHASSIS ASSY (FOR TAJIMI) | 1 |
| G04 | 24X0258 | TU-RECT/RECT SUB ASSY | 1 |
| G05 | 24E0065 | TU-MB | 1 |
| G06 | 24E0066 | TU-INCOM (LED) | 1 |
| G07 | 24X0259 | BNC | 1 |
| G08 | 24E0067 | REMOTE | 1 |
| G09 | 24E0068 | TU-MIC | 1 |
| G10 | 24X0260 | REAR PANEL (TU-DC IN) | 1 |
| G20 | 24X0256 | DU-CHASSIS (FOR KINGS) | 1 |
| G20 | 24X0274 | DU-CHASSIS (FOR FISGER) | 1 |
| G20 | 24X0275 | DU-CHASSIS (FOR TAJIMI) | 1 |
| G21 | 24X0257 | DU-MOD/DEM (FOR NTSC) | 1 |
| G21 | 24X0276 | DU-MOD/DEM (FOR PAL) | 1 |
| G22 | 24E0064 | FIL-VA | 1 |